

ÜRÜN KATALOĞU  
HAVVALANDIRMA  
MAKİNALARI



PRODUCT CATALOGUE  
HVAC MACHINES



[www.demecmakina.com.tr](http://www.demecmakina.com.tr)

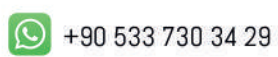
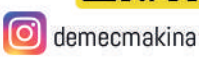



## SAYGIN MAKİNALAR

### HAKKIMIZDA

Ortaklarının ihtiyaçlarına yönelik hizmet ve ürünler sunan, üretim kalitelerini arttıran ve kendisini sürekli geliştiren Demeç Makina, girişimci, yenilikçi ve sorumluluk tanıyan vizyoner ruhuyla 2018 yılında kurulmuştur. Makina sanayisinde başladığı faaliyetlerine sahip olduğu ilke ve değerleri de katarak kısa sürede aranan ve talep duyulan bir firma haline gelmiştir. Demeç Makina geçen yıllar içerisinde yurtiçinde ve yurtdışında sunmuş olduğu yüksek kaliteli ürünler ve satış sonrası hizmetleri ile Türk makina sanayisini başarıyla temsil etmektedir. Kısa sürede gerçekleşen bu hızlı büyüme ,zamanla istikrara dönüşmüş ve Demeç Makina, makina sanayisinin saygın ve güvenilir kuruluşları arasında yerini almıştır.

## CRAFTED MACHINES

### ABOUT US

Demec Machinery, which provides services and products for the needs of its business partners, increases their production quality and constantly improves itself, was established in 2018 with its entrepreneurial, innovative and responsible visionary spirit. By adding its principles and values to its activities that it started in the machinery industry, it has become a sought-after and demanded company in a short time. Demec Machinery has been successfully representing the Turkish machinery industry with its high quality products and after-sales services, which it has offered at home and abroad in the past years. This rapid growth in a short time has turned into stability over time and Demec Machinery has taken its place among the respected and reliable companies of the machinery industry.

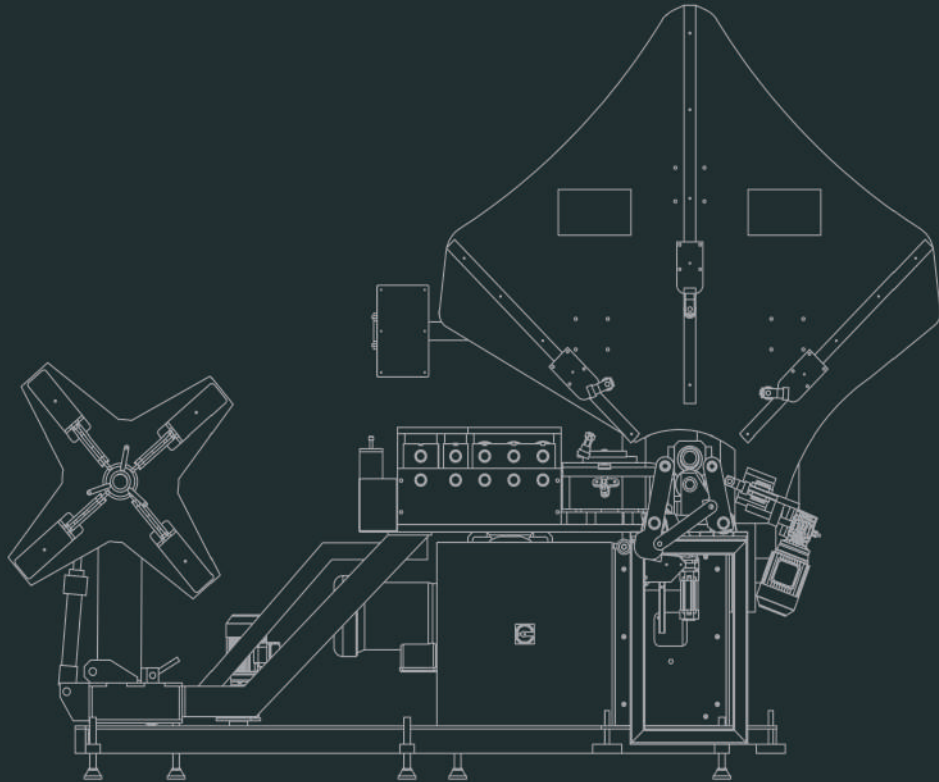

## NEDEN DEMEEC MAKİNA ?

- 1-Kalite, uzun yılların getirmiş olduğu bir kazanımdır bu yüzden firmamız müşteri odaklı çalışır.
- 2-İhtiyaçlarınıza uygun esnek üretim yapar, çözüm odaklı ürünler sunar.
- 3-Bilgi kirliliği yoktur, satış aşamasından teslimata kadar aklınıza takılacak her türlü soruya kesin cevaplar verilir.

## WHY DEMEEC MACHINERY ?

- 1-Quality is an achievement of many years, so our company works customer-oriented.
- 2-Makes flexible production according to your needs, offers solution-oriented products.
- 3-There is no information pollution, from the sales stage to the delivery, you will be given exact answers to any questions you may have.



# TOKM01 TAM OTOMATİK KELEPÇE MAKİNASI

## TOKM01 FULLY AUTOMATIC CLAMPING MACHINE

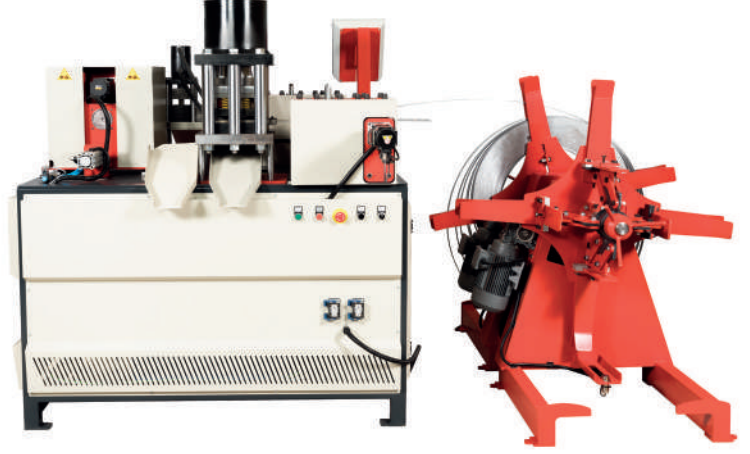

### TOKM01 Tam Otomatik Kelepçe Makinası

Makinamız havalandırma sektöründe kullanılan yuvarlak kanalların kelepçe üretimini gerçekleştirmektedir. çap 100 mm / 1250 mm arası yirmidört farklı çapta kanal üretebilmektedir ayrıca 1,50 mm'den 2,50 mm'e kadar kalınlıkta sac işleme kapasitesine sahiptir.

### TOKM01 Fully Automatic Clamping Machine

Our machine performs the ventilation production of round ducts used in the ventilation sector. It can produce ducts in twenty-four different diameters between diameter 100 mm / 1250 mm and also has sheet metal processing from 1.50 mm to 2.50 mm.

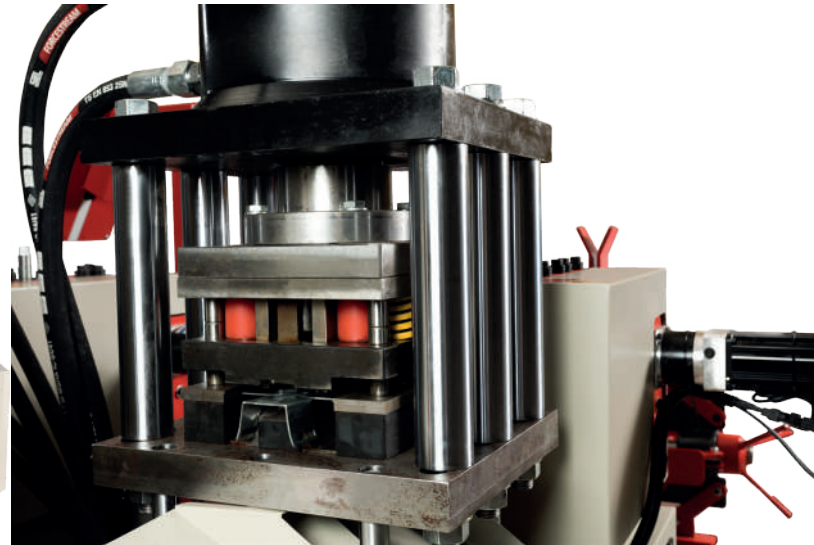
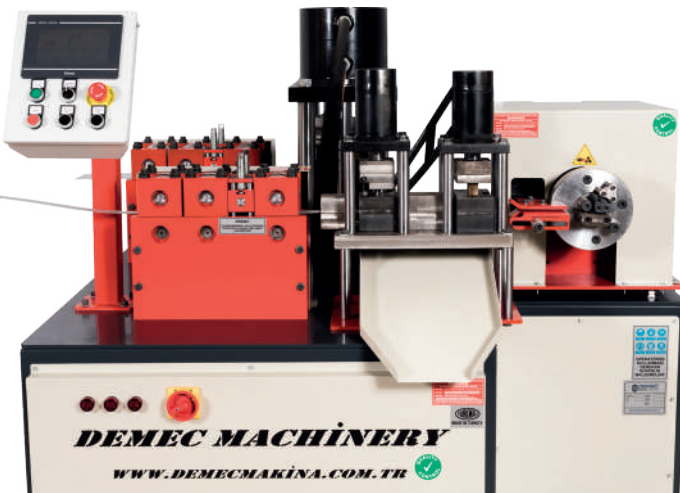

# TOKM01 TAM OTOMATİK KELEPÇE MAKİNASI

## TOKM01 FULLY AUTOMATIC CLAMPING MACHINE

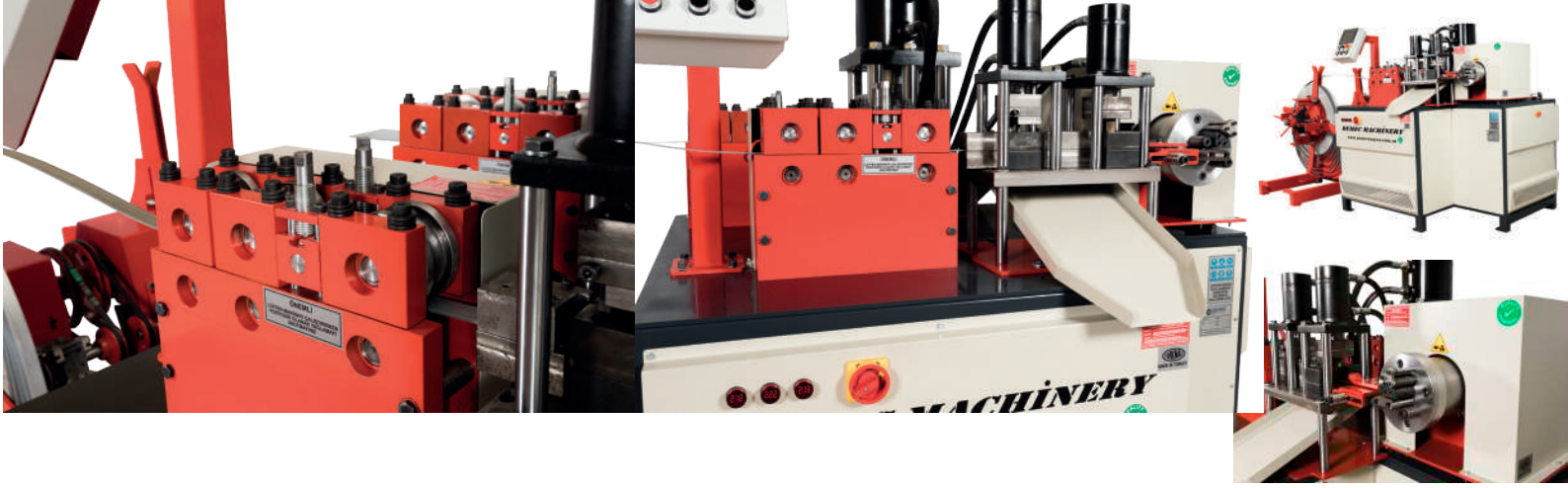

Çap Ayarı / Diameter Set Up	100mm - 1250mm
Sac Kalınlığı / Sheet Thickness	1,50mm - 2,50mm
Güç / Strength	Servo Sistem / Servo System
Gerilim / Voltage	380V AC / 3 PH / 50 - 60 Hz
Ebatlar / Dimensions	3000mm x 1500mm x h:1700mm
Hidrolik / Hydraulic	60ton
Besleme / Feed	Otomatik Rulo Açıcı 500Kg Kapasite / Automatic Uncoiler 500Kg Capacity
Ağırlık / Weight	1000 Kg
Opsiyonlar / Options	Renk / Marka İsmi / Color / Brand Name

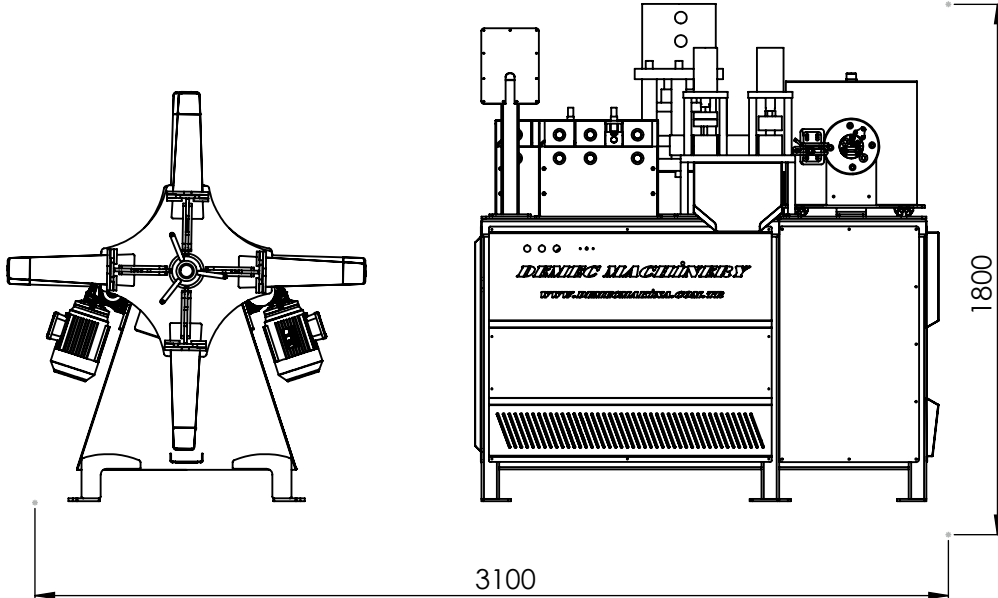
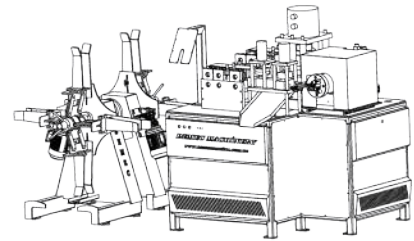



Tip Type	DFM 20/25/30/35/40	Gerilim Voltage	380V AC/ 3 PH / 50 - 60 Hz
Sekil Form	TDC	Hava Basıncı Air Pressure	6-8 Bar
Rulo Tasıma Kapasitesi Roll Opener Capacity	600 Kg	Üretim Hızı Production Speed	8 m/dk 8 m/min
Rulo Açıcı Gücü Roll Opener Power	Manuel	Kesim Sekli Cutting Type	Otomatik Gezer Testere Flying Saw Unit
Sac Genisliği Sheet Metal Width	90 mm / 97 mm / 104 mm/ 111 mm / 118 mm	Testere Çapı Saw Diameter	315 mm
Sac Kalınlığı Sheet Thickness	Galvaniz 0,50 mm/0,60 mm Galvanized Steel 0,50 mm/0,60 mm	Kesme Uzunluğu Cutting Length	Limitsiz * Servo Sistem / Pnömatik Limitless * Servomotor / Pneumatic
İstasyon Sayısı Station Quantity	20	Sızdırmazlık Sealing	Silikon Pompası Silicone Pump
Kontrol Sistemi Control Unit	Dokunmatik Ekran /PLC Touch Panel / PLC	Ebatlar Dimensions	6000mm x 6000mm x h:1500mm
Güç Power	5,5 Kw	Ağırlık Weight	2500 Kg
		Opsiyonlar Options	Renk / Marka ismi Colour / Brand Name

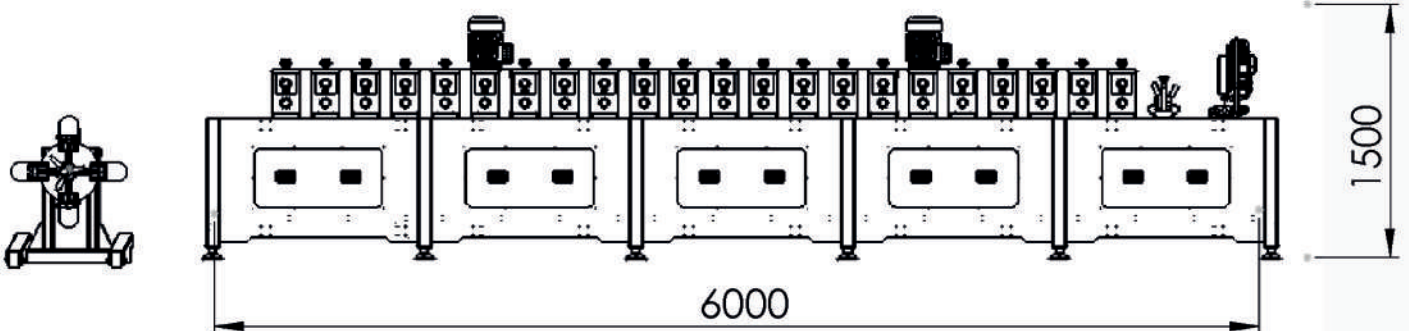

# 20-25-30-35-40 TDC FLANGE MACHINE

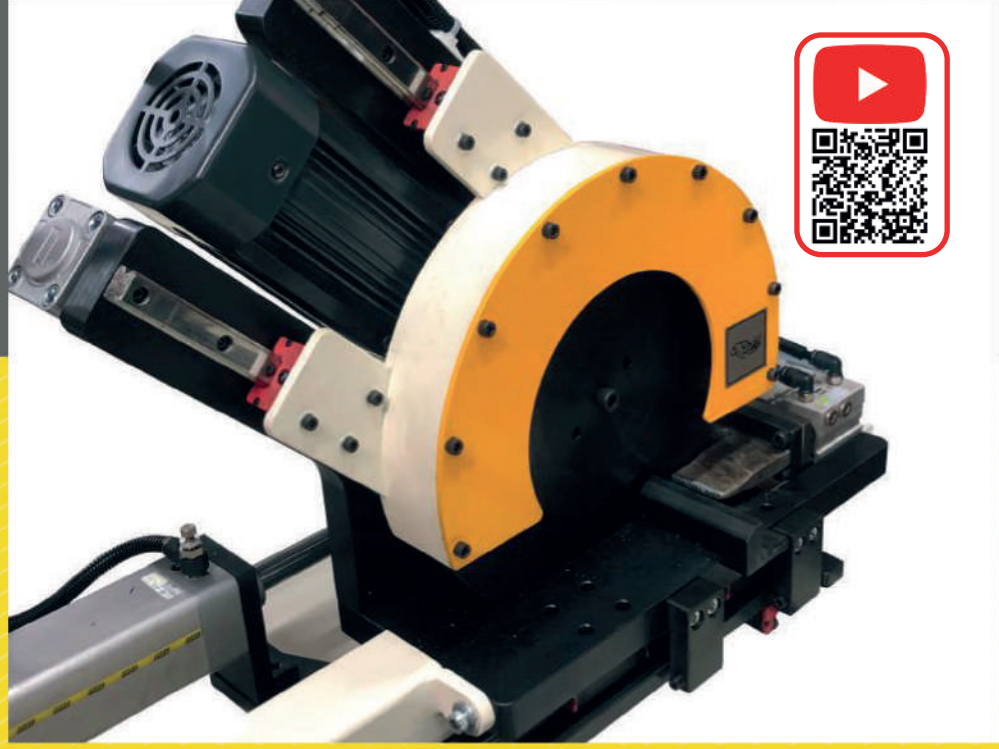
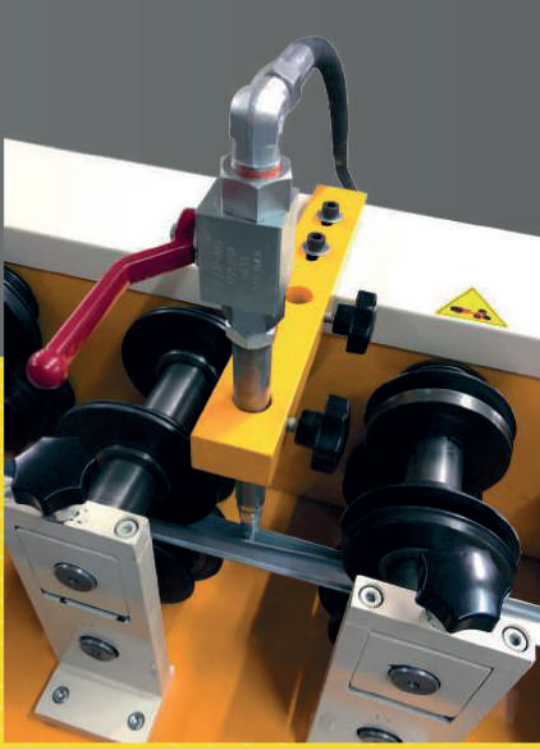

Makinamız havalandırma sektöründe kullanılan kare kanalların birbirleriyle montajı için gerekli TDC tip flanş üretimi yapmaktadır. Talebe göre silikon pompalı olmak üzere 20-25-30-35-40 tiplerinde üretilebilir.

Our machine produces TDC type flanges required for the assembly of prismatic ducts used in the ventilation sector. It can be produced in 20-25-30-35-40 types, with or without silicone unit, according to demand.

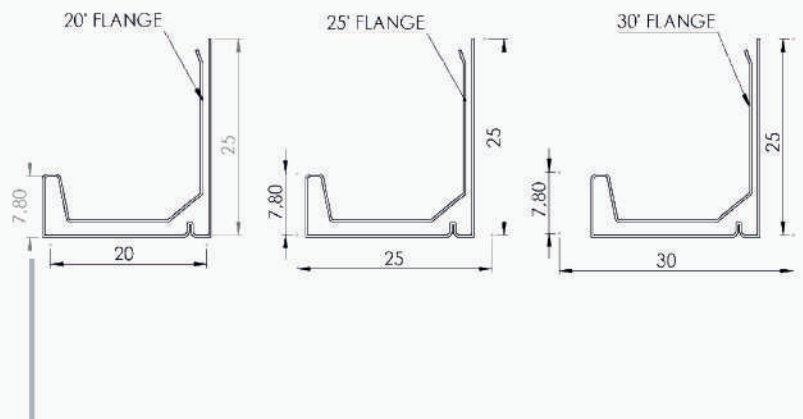
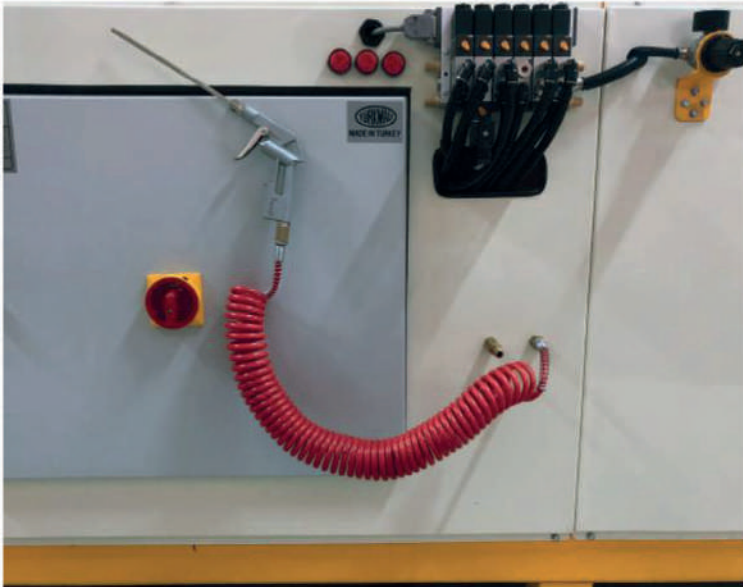

# DTF01 YUVARLAK KANAL MAKİNASI

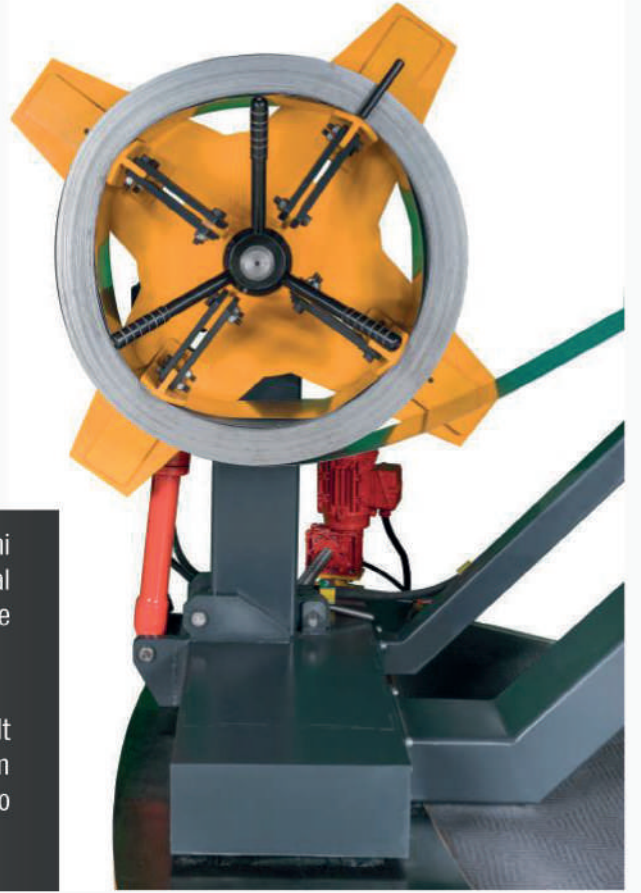

Makinamız havalandırma sektöründe kullanılan yuvarlak kanalların üretimini gerçekleştirmektedir. 100mm/1250mm arası yirmidört farklı çapta kanal üretebilmektedir ayrıca 0,50mm'den 1,20 mm'e kadar kalınlıkta sac işleme kapasitesine sahiptir.

Our machine manufactures the spiral ducts (tubes) used in the HVAC sector. It can produce twenty-four different diameters between 100mm up to 1250mm and it has the capacity to process sheet metal thicknesses from 0.50mm to 1.2mm.

- \* Otomatik açı ayarlama sistemi
- \* Tam otomatik PLC kontrol sistemi
- \* Üretim hızı ayar sistemi
- \* 100 mm - 1250 mm çap ayarı
- \* 11 KW motor gücü
- \* 600 Kg rulo açıcı kapasitesi
- \* Hidrolik rulo yükleme sistemi
- \* Hidrolik kenet sistemi
- \* Özel tasarım otomatik plazma kesim ünitesi
- \* Ürün istifleme tezgahı



- \* Automatic angle adjustment
- \* Full automatic PLC control system
- \* Variable production speed
- \* From 100 mm up to 1250 mm producing capability
- \* 11 KW motor power
- \* 600 Kg roll opener capacity
- \* Hydraulic loading system for roll metal
- \* Hydraulic power system for locking
- \* Customized plasma cutting system
- \* Product collection bench

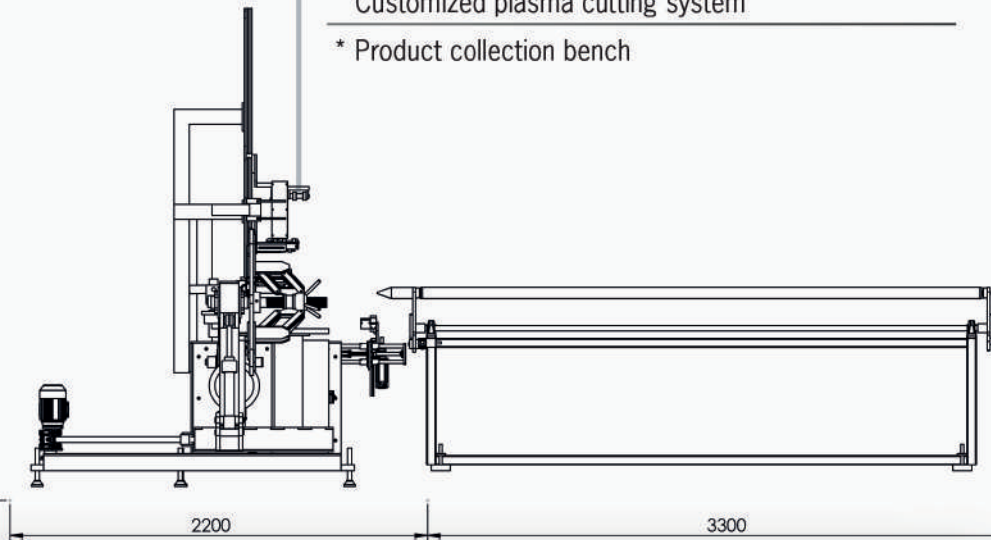
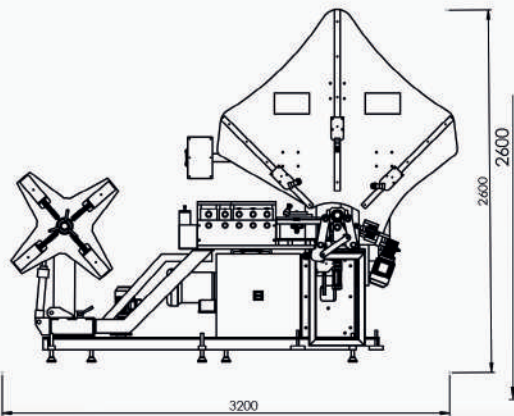



# DTF01 SPIRAL TUBE MACHINE

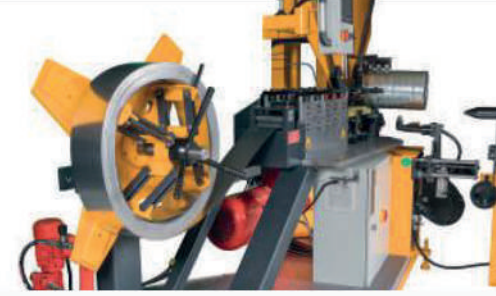
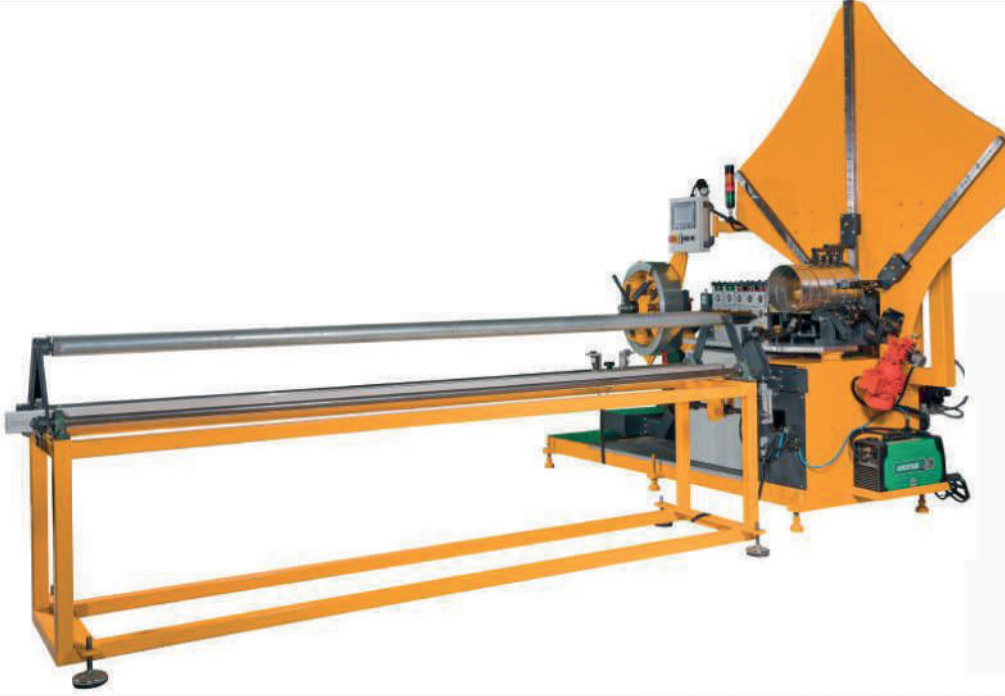

Tip/Type

DTF-01

Çap Ayarı/Diameter Set Up

Manuel

Çap Sayısı/Diameter Quantity

24 adet/24 Pcs

Desen Tipi/Profile Type

Tek Tip/Single Trace

Rulo Taşıma Kapasitesi/ Roll Opener Capacity

600 Kg

Rulo Açıcı Gücü/Roll Opener Power

Hidrolik Yükleme /Hydraulic Loading System

Sac Geniřliđi/Sheet Metal Width

137 mm

Sac Kalınlıđı/Sheet Metal Thickness

Galvaniz: 0,50mm / 1,2mm - Krom: 0,50mm / 0,70mm

Galvanized Steel: 0,50mm / 1,2mm - Chromium: 0,50mm / 0,70mm

İstasyon Sayısı/Station Quantity

5

Kontrol Sistemi/Control Unit

Dokunmatik Ekran / PLC/ Touch Panel / PLC

Güç /Power

11 KW

Gerilim/Voltage

380V AC / 3PH / 50 - 60 Hz

Hava Basıncı/Air Pressure

6-8 Bar

Üretim Hızı/Production Speed

Ø100 mm - 12 m/dk, Ø500 mm - 2,5 m/dk , Ø1000 - 1m/dk  
Ø100 mm - 12 m/min Ø500 mm - 2,5 m/min, Ø1000 - 1m/min

Kesim Şekli/Cutting Type

Otomatik Plazma / Automatic Plasma

Çalışma Uzunluđu / Working Length

150 mm / 3000 mm

Ebatlar/Dimensions

3200 mm x 5500mm x h:2600mm

Ağırlık /Weight

1700 Kg

Opsiyonlar/Options

Renk / Marka İsmi/ Colour/ Brand Name

# DLC01 DİRSEK MAKİNASI

## DLC01 GORELOCKER



Tip Type	DLC - 01
Kontrol Sistemi Control Unit	Manuel Pano Manuel Board
Hava Basıncı Air Pressure	6 - 8 Bar
Üretim Hızı Production Speed	Ayarlanabilir Hidromotor Hızı Variable Hydromotor Speed
Çap Ayarı Diameter Set Up	Manuel
Çap Sayısı Diameter Quantity	23 Adet 23 Pcs
Sac Kalınlığı Sheet Metal Thickness	Galvaniz: 0,50 /1,2 mm - Galvanized Steel 0,50mm / 1,2 mm Krom: 0,50 mm /0,70 mm - Chromium 0,50mm / 0,70mm
Güç Power	4 KW
Ebatlar Dimensions	3000 mm x 1000mm x h: 1000 mm
Ağırlık Weight	850 Kg
Opsiyonlar Options	Renk / Marka ismi Colour/ brand Name

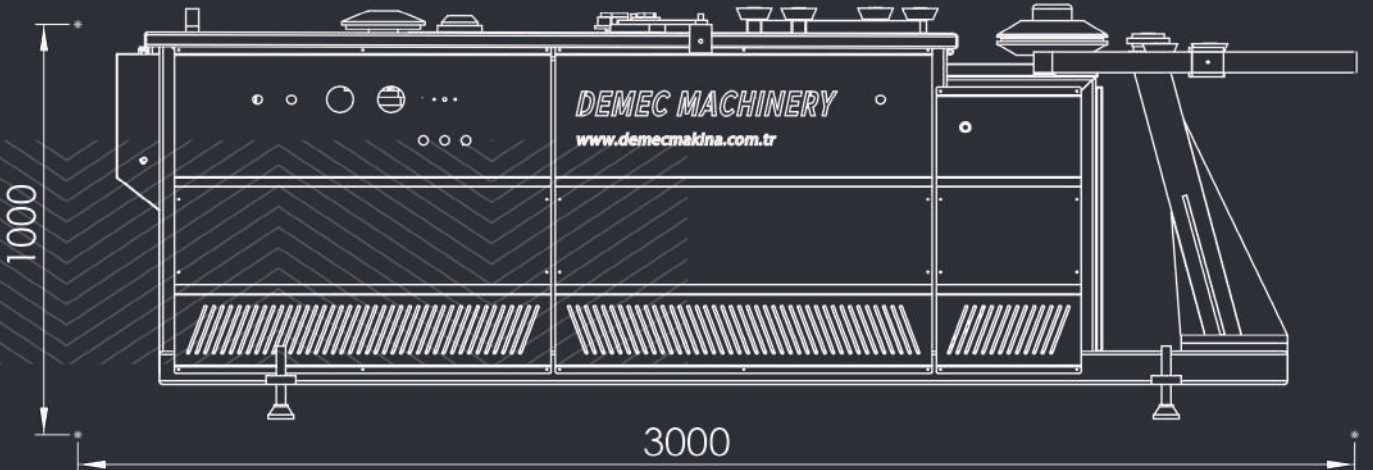

# DLC01 DİRSEK MAKİNASI

## DLC01 GORELOCKER



Makınamız havalandırma sektöründeki yuvarlak kanalların üzerinde kullanılan dirseklerin üretimini gerçekleştirmektedir. 125mm / 1250mm arası yirmi üç farklı çapta dirsek üretebilmektedir ayrıca 0,50mm'den 1,20 mm'e kadar kalınlıkta sac işleme kapasitesine sahiptir.

Our machine produces the elbows used on the round ducts in the ventilation sector. It can produce elbows in twenty-three different diameters between 125mm / 1250mm, and it has the capacity to process sheet metal in thicknesses from 0,50mm to 1,20mm.

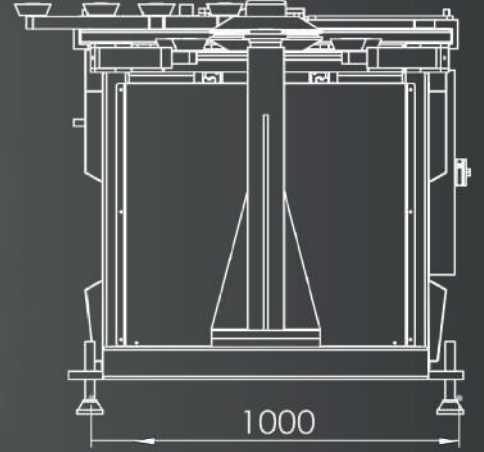

# PRİZMATİK KANAL MAKİNASI

## PRISMATIC DUCT MACHINE



Tip Type	Hidrolik / Otomatik Hydraulic / Automatic
Kontrol Sistemi Control Unit	Dokunmatik Ekran / PLC Touch Panel / PLC
Rulo Taşıma Kapasitesi Roll Opener Capacity	5000 Kg x 2 Adet 5000 Kg x 2 Pcs
Üretim Hızı Production Speed	200 x 200 mm 1 Adet / dk 200 x 200 mm 1 pcs / min
Sac Geniřlięi Sheet Metal Width	1500 mm
Desen Tipi Profile Type	Trapez / Baklava Trapeze / Straight
Sac Kalınlıęı Sheet Thickness	0,50mm - 1,20mm
Kesim Őekli Cutting Type	Otomatik
Güç Power	2,2 KW
Gerilim Voltage	380V AC / 3 PH / 50 - 60 Hz
Ebatlar Dimensions	2000mm x 2000mm x h:1600mm
Aęırlık Weight	2900 Kg
Opsiyonlar Options	Renk / Marka İsmi / Etiket Ünitesi Colour / Brand Name / Label Unit

Makinamız 0,5mm - 1,2mm arasında galvaniz kaplama sacları işleyebilmektedir. Üzerinde bulunan PLC kontrol sistemi sayesinde çok hassas çalışmaktadır ayrıca büküm ünitesi hidrolik güçle beslenmektedir.

Tam otomatik çalışma  
2 adet rulo açıcı  
Sac düzleştirme sistemi  
Hidrolik güç ünitesi

Our machine can process galvanized sheet metal between 0.5mm - 1.2mm. With the control of PLC system on it, it works very sensitively also bending unit is fed by hydraulic power unit.

Full automatic  
2 pcs roll sheet decoiler  
Sheet metal straightener  
Hydraulic power unit

# KANAL KAPATMA MAKİNASI SEAM LOCKER



Kare ve dikdörtgen biçimli havalandırma kanallarının kenetlenmesini sağlar. 0,5 mm ve 1,2 mm arasında bütün sacların kapatmasını yapabilir. Güçlü kenet sistemi sayesinde kanallarda hava sızdırmazlığını minimum seviyeye indirir. Makina üzerinde kullanılan makaraların hepsi 2379 tip çelikten imal edilmektedir ayrıca dayama tablaları paslanmaya karşı galvanizli sacdan imal edilip müşteri talebine göre boyanmaktadır.

It provides locking of square and rectangular shaped ventilation ducts. It can work with all thickness between 0.5 mm and 1.2 mm galvanized steel. With its strong locking system, it reduces the air tightness in the ducts to a minimum. All of the rollers used on the machine are made of 2379 type steel, and the support plates are made of galvanized sheet against corrosion and painted according to customer demand.

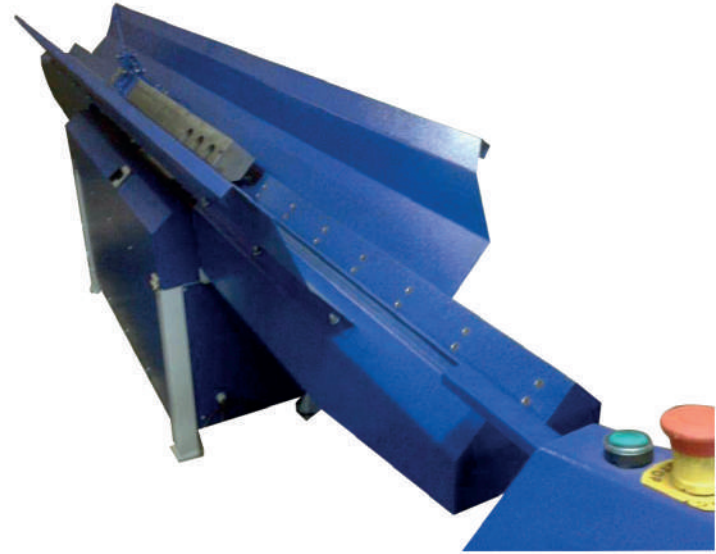

Kontrol Sistemi Control Unit	Manuel Pano Manuel Board
Üretim Hızı Production Speed	5 m / dk 5 m / min
Sac Kalınlığı Sheet Thickness	Galvaniz: 0,50mm / 1,2mm - Galvanized Steel 0,50mm / 1,2mm Krom: 0,50mm / 0,70mm - Chromium 0,50mm / 0,70mm
Güç Power	3 KW

Gerilim Voltage	380V AC / 3 PH / 50 - 60 Hz
Ebatlar Dimensions	850 mm x 4800 mm x h: 1050 mm
Ağırlık Weight	730 Kg
Opsiyonlar Options	Renk / Marka İsmi Colour / Brand Name



demecmakina



demec.makina



+90 533 730 34 29